

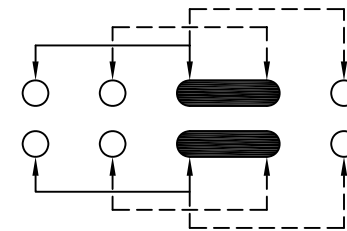

CAD FILE:

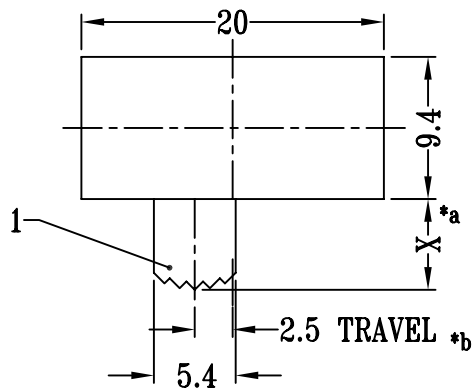

SCHEMATIC (SHORTING)

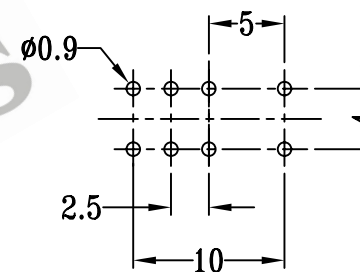
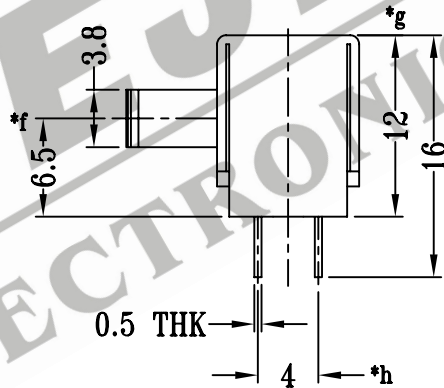
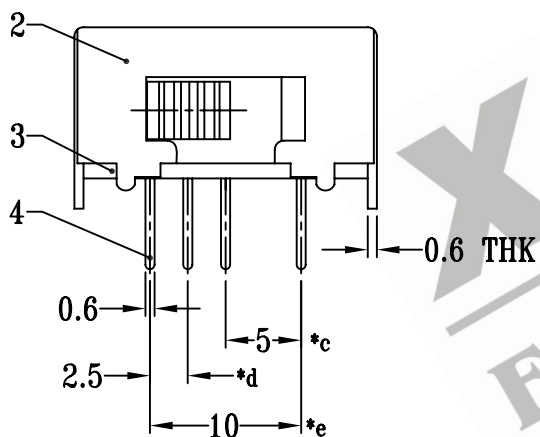

P.C.B LAYOUT

注:带"\*"表示关键尺寸(8个)

NO.	PART NAME	MATERIAL	QTY	FINISHING	TOLERANCE UNLESS SPECIFIED	SHENZHEN XIEJIA ELECTRONICS CO.,LTD.				
8						ISSUE	DATE	DESCRIPTIONS		APPD
7	STEEL STRIP	STEEL	1	NATURAL	WITHIN: 1.5±0.1mm OVER: 1.5±0.2mm					
6	SPRING	STAINLESS STEEL	1	TEMPER				DRWG NO.: XJ-DR-SK23E07-00		
5	CONTACT (CLIP)	PBS STRIP	2	Ag PLATED				SCALE: 2:1		
4	TERMINAL	BRASS STRIP	8	Ag PLATED OVER Ni PLATED	TITLE: HORIZONTAL SLIDE SWITCH			DWN	ZHOUYU	2007-5-31
3	TERMINAL BASE	PHENOLIC RESIN	1	NATURAL	MODEL: SK-23E07			CHK'D	FANGYING	2007-5-31
2	FRAME	STEEL STRIP	1	Ni PLATED	ALL MATERIALS MUST BE COMPLIANT TO ROHS			APPD	KANGXINAN	2007-5-31
1	KNOB	POM	1	BLACK						